

# Ambient Response Analysis of the Great Belt Bridge

*Rune Brincker*  
*Department of Building Technology and Structural Engineering*  
*Aalborg University*  
*Sonhgaardsholmsvej 57, DK 9000, Aalborg, Denmark*

*Jannette B. Frandsen*  
*Department of Engineering Science*  
*University of Oxford*  
*Parks Road, Oxford OX1 3PJ, England*

*Palle Andersen*  
*Structural Vibration Solutions ApS*  
*NOVI Science Park,*  
*Niels Jernes Vej 10, DK 9220 Aalborg East, Denmark*

## Abstract

In this paper an ambient response analysis of the Great Belt Bridge is presented. The Great Belt Bridge is one of the largest suspension bridges in the world, and the analysis was carried out in order to investigate the possibilities of estimating reliable damping values from the ambient response due to traffic and wind. The response data were analysed using three different techniques: a non-parametric technique based on Frequency Domain Decomposition (FDD), a parametric technique working on the raw data in time domain, a data driven Stochastic Subspace Identification (SSI) algorithm and finally a covariance driven SSI technique. In a small frequency band from 0.17-0.30 Hz 5 modes were identified, and the quality of the modal estimates were evaluated based on MAC values on the mode shapes estimates and standard deviations on damping estimates.

## Nomenclature

$\Delta t$	sampling time step
$y_t$	response vector
$f$	natural frequency
$\zeta$	damping ratio
$\Phi, \Psi$	mode shape matrices

## Introduction

When modal properties are to be identified from large structures, usually the possibilities to control and measure

the loading on the structure is rather limited. This is especially true for very large bridges where the excitation of the low frequency modes by artificial loading is difficult. Further, since the bridge is carrying heavy traffic 24 hours a day, the ambient response will in any case be a dominating signal. Thus, in stead of trying to control the loading and reduce the response from ambient loads, in this case the ambient response was used as data for an output only modal identification.

Several real cases of ambient response analysis can be found in Ventura and Horyna [1], and a comparison between different techniques for modal identification from ambient responses can be found in Andersen et al. [2].

The main purpose of this investigation was to make a survey on the possibilities of estimating the total damping from ambient response measurements only. The investigation was carried out on the Great Belt bridge in Denmark, a suspension bridge with a closed box-girder and a free span of 1624m. Earlier an investigation of the structural damping of the same bridge has been carried out, Jensen et al. [3]. However, in this earlier investigation only one technique was used for identification.

The purpose of this investigation was to make an independent identification of the bridge using different identification techniques and to compare the different techniques evaluating the quality of the modal identification

Long-span bridge design is dominated by aeroelastic stability considerations involving a complex interaction between bluff-body unsteady fluid dynamics and structural response. The structural damping and the damping introduced by the flow around the structure plays a central

role. The classical wind tunnel tests can only be used as a guide-line since the high Reynolds number present in full-scale cannot be reproduced at model-scale level.

Thus, the long term goal of this investigation is to establish a procedure for modal identification of large bridges so that reliable damping estimates can be obtained and the influence from the wind can be accurately obtained. The aim is to establish the relation between the damping and the wind speed so that the amplitudes of wind induced oscillations can be more accurately obtained.

In this particular case four time series were acquired, all at the same day. During the measurements, the wind direction and speed was recorded to be almost constant, a North-West wind at about 6 m/s. Since the wind was not close to be perpendicular to the bridge line no severe vortex-induced oscillations was expected, and thus, the damping values presented in this paper are assumed to be representative for traffic induced vibrations.

The four test cases, in the following denoted test4, test5, test6 and test7, were performed using the same transducer set-up. Transducers were 8 DC accelerometers placed in three cross sections along the main bridge deck, see Figure 1. The measurement cross sections were placed between the two main pylons approximately one third of the distance between the pylons from the west pylon. The transducers had a sensitivity of 40 V/g, and the signals were sampled at approximately 200 Hz using a 16 bit data acquisition system. Afterwards, the signals were decimated by 125 to a sampling frequency of 1.58 Hz corresponding to a Nyquist frequency of 0.791 Hz. The length of decimated time series was 6000 data per channel for test4, test5 and test7 and 12000 data points per channel for test6. This corresponds to about 1 hour measurements for the short time series and about 2 hours for the long time series.

The response data were analysed using three different techniques: a non-parametric technique based on Frequency Domain Decomposition (FDD), a parametric technique working on the raw data in time domain, a data driven Stochastic Subspace Identification (SSI) algorithm, and finally a covariance driven SSI algorithm.

Because of difficulties using parametric models on data with a large number of modes, the data were band-pass filtered to concentrate on the frequency region 0.17-0.30 Hz.

The results from the three techniques were compared and validated against each other.

## **Principle of Frequency Domain Decomposition (FDD)**

The Frequency Domain Decomposition (FDD) technique is an extension of the classical frequency domain approach often referred to as the Basic Frequency Domain (BFD) technique, or the peak picking technique. The classical approach is based on simple signal processing using the Discrete Fourier Transform, and is using the fact, that well separated modes can be estimated directly from the power spectral density matrix at the peak.

In the FDD technique first the spectral matrix is formed from the measured outputs using simple signal processing by discrete Fourier Transform (DFT). However, instead of using the spectral density matrix directly like in the classical approach, the spectral matrix is decomposed at every frequency line using Singular Value Decomposition (SVD). By doing so the spectral matrix is decomposed into a set of auto spectral density functions, each corresponding to a single degree of freedom (SDOF) system. This is exactly true in the case where the loading is white noise, the structure is lightly damped, and where the mode shapes of close modes are geometrically orthogonal. If these assumptions are not satisfied, the decomposition into SDOF systems is an approximation, but still the results are significantly more accurate than the results of the classical approach.

The singular vectors in the SVD are used as estimates of the mode shape vectors, and the natural frequencies are estimated by taking each individual SDOF auto spectral density function back to time domain by inverse DFT. The frequency and the damping were simply estimated from the crossing times and the logarithmic decrement of the corresponding SDOF auto correlation function.

The theoretical background of the FDD technique is described in Brincker et al. [4].

## **Results of Frequency Domain Decomposition (FDD)**

Figure 2 shows the singular value decomposition of the spectral density matrix of test4. In this identification, the measurements had 6 channels of response data. Thus, the decomposition results in 6 singular values.

As it appears, more than 15 modes seems to be present in the frequency range from 0-0.7 Hz. Further, most of the modes seems to be well separated, but around 0.28 Hz two close modes are present. For the band-pass filtered data, 5 modes are clearly visible including the mentioned set of close modes around 0.28 Hz.

All 5 modes were easily identified using the FDD technique for all test cases. The results are given in tables 1-4. In all cases the spectral density function were estimated using

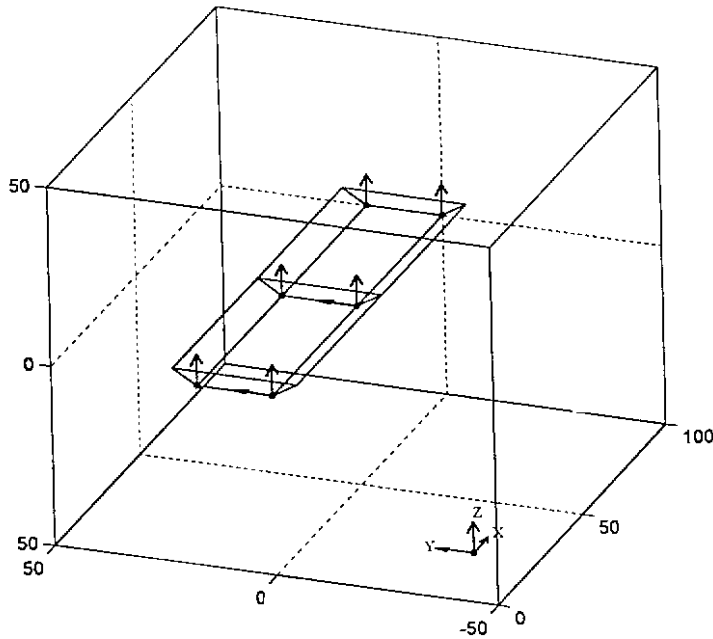

Figure 1. Transducer set-up. Distances between the three cross sections are approximately 70 m

1024 point FFT except in the case of test6 where the spectral densities were also calculated using 2048 point FFT. The corresponding values of the damping are given in brackets in table 3. Mode shapes for test4 are shown in Figure 5.

### Principle of Stochastic Subspace Identification (SSI)

Stochastic Subspace Identification (SSI) is a class of techniques that are all formulated and solved using state space formulations of the form

$$\begin{aligned} x_{t+1} &= Ax_t + w_t \\ y_t &= Cx_t + v_t \end{aligned}$$

where  $x_t$  is the Kalman sequences that in SSI is found by a so-called orthogonal projection technique, Overschee and De Moor [6]. Next step is to solve the regression problem for the matrices  $A$  and  $C$ , and for the residual sequences  $w_t$  and  $v_t$ . Finally, in order to complete a full covariance equivalent model in discrete time, the Kalman gain matrix  $K$  is estimated to yield

$$\begin{aligned} \hat{x}_{t+1} &= A\hat{x}_t + Ke_t \\ y_t &= C\hat{x}_t + e_t \end{aligned}$$

It can be shown, Brincker and Andersen [5], that by performing a modal decomposition of the  $A$  matrix as  $A = V[\mu_i]V^{-1}$  and introducing a new state vector  $z_t = V^{-1}\hat{x}_t$ , the equation can also be written as

$$\begin{aligned} z_{t+1} &= [\mu_i]z_t + \Psi e_t \\ y_t &= \Phi z_t + e_t \end{aligned}$$

where  $[\mu_i]$  is a diagonal matrix holding the discrete poles related to the continuous time poles  $\lambda_i$  by  $\mu_i = \exp(\lambda_i \Delta t)$ , and where the matrix  $\Phi$  is holding the left hand mode shapes (physical, scaled mode shapes) and the matrix  $\Psi$  is holding the right hand mode shapes (non-physical mode shapes). The right hand mode shapes are also referred to as the initial modal amplitudes, Juang [7].

The specific technique used in this investigation is the Principal Component algorithm, see Overschee and De Moor [6].

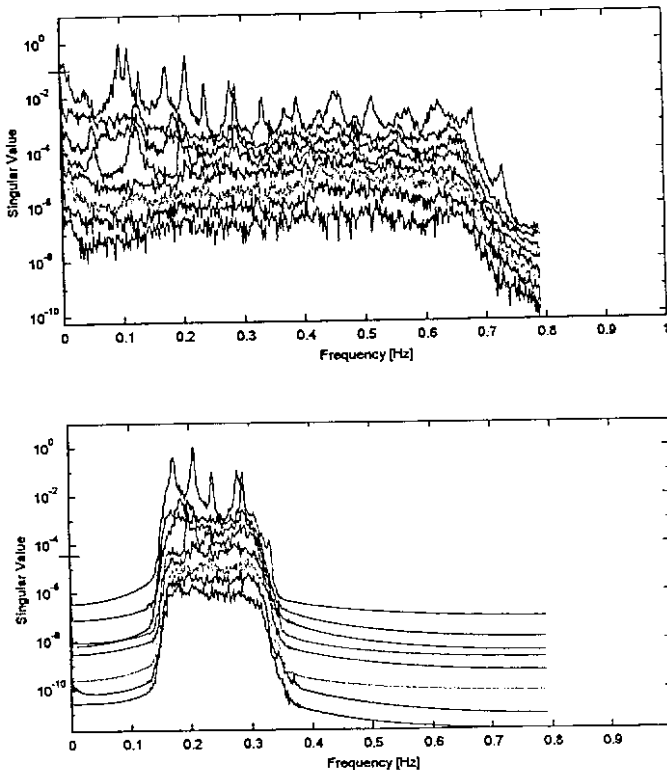

Figure 2. Singular value decomposition of the spectral density matrix of the test4, top: unfiltered data, bottom: band-pass filtered data.

## Results of Stochastic Subspace Identification (SSI)

For each test case a set of models with different model orders were identified and the stabilisation diagram was established. Figure 3 shows the stabilisation diagram for the data driven SSI for test4.

For the covariance driven SSI, the covariance function were estimated using the Random Decrement technique which provides unbiased and low variance covariance function estimates, Asmussen [5]. Figure 4 shows the stabilisation diagram for the covariance driven SSI for test4.

As it appears, SSI has some problems handling this case. Even though the five peaks appear quite clearly in both spectral densities and decomposed spectral densities, the modes are not clearly indicated in the stabilisation diagrams. This problem was even more severe before band-pass filtering the signals. Further, there does not seem to be much difference between the modal indication (stabilisation) for the data driven and the covariance driven SSI. For the case

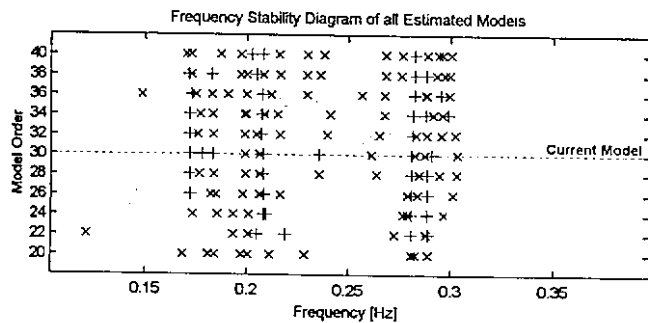

Figure 3. Stabilisation diagram of test4 (zoomed). Data driven SSI.

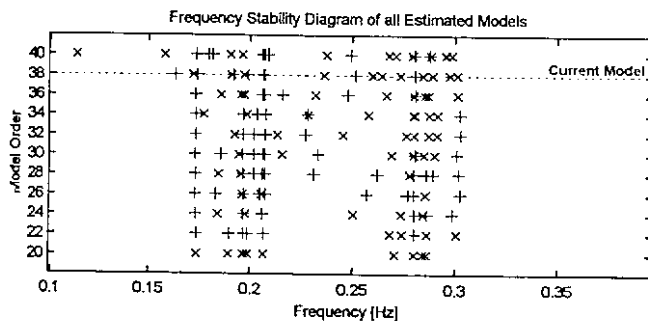

Figure 4. Stabilisation diagram of test4 (zoomed). Covariance driven SSI.

of test4 shown in Figure 3 and 4 it might look like the data driven SSI stabilise better. However, results for the other cases does not support this conclusion.

The 5 modes were not easily identified using the SSI technique on the four test cases, however, identification was possible in the most cases. The results are given in tables 1-4. Mode shapes for test4 are shown in Figure 5.

## Evaluation of results

The quality of the two SSI techniques were evaluated comparing the estimated mode shapes with the mode shape estimates from FDD. The mode shapes were compared using the MAC values, see tables 1-4. As it appears from the results, the difference between the data driven and the covariance driven SSI is rather small, but it seems like the data driven SSI in general has a little more reliable mode shape estimates than the covariance driven. SSI has severe problems identifying the fifth mode. For test4 the identification of the fifth mode failed for both the data driven and the covariance driven SSI.

Since the FDD technique is based on traditional spectral estimation that introduces leakage bias, it was expected that the quality of the damping estimates from FDD would be rather poor compared to estimates obtained by a parametric model like SSI. This expectation was reinforced by the fact that damping values were small, typically smaller than 1 %.

The quality of the damping estimates can be evaluated by calculating the standard deviation over the four test cases. Results are given in table 5. As it appears from the results, the FDD technique has much less uncertainty on the damping estimates than the SSI technique. If the mean of the standard deviation over the modes is considered, FDD is clearly better than SSI, if the maximum standard deviation is considered, FDD is clearly better than SSI, and finally if the minimum standard deviation is considered, FDD is as good as SSI. The somewhat surprising conclusion is that FDD is to prefer from SSI when accurate damping estimates are of importance. However, in the cases where 1024 data point were used in the FFT, results indicate that the FDD damping estimates were biased by leakage. This can be concluded comparing the results for the 1024 data point FFT with the results of the 2048 data point FFT. As it appears, the 2048 data point FFT had smaller damping estimates in all cases.

## Conclusions

The signals were band-pass filtered and five modes were identified in a narrow frequency range from 0.17-0.29 Hz. Two of the five mode were close modes.

There was not much difference between the results of the data driven and the covariance driven SSI technique. In general the SSI techniques had difficulties identifying all five modes, and the damping estimates were rather uncertain.

The FDD technique easily identified all five modes for all four test cases. Damping values were judged to be biased by leakage, however, the damping estimates were evaluated to be significantly better than the estimates obtained by SSI.

For all five modes the damping was estimated to small values less or around 1 % damping.

The length of the time series should not be shorter than 1 hour. If possible the length of the time series should be 2 hours or more to minimise the leakage bias on the damping estimation when using FDD.

## References

- [1] Ventura, Carlos E. and Tomas Horyna: "Structural Assesment by Modal Analysis in Western Canada". Proc. of the 15<sup>th</sup> International Modal Analysis Conference, Orlando, Florida, Orlando, 1997.
- [2] Andersen, P, R. Brincker, B. Peeters, G. De Roeck, L. Hermans and C. Krämer: "Comparison of system Identification Methods Using Ambient Bridge Test Data", Proc. of the 17<sup>th</sup> International

Modal Analysis Conference, Kissimee, Florida, 1999.

- [3] Laigaard Jensen, J., A. Larsen, J.E. Andersen and T. Vejrum: "Estimation of Structural Dmping of the Great belt suspension bridge". Proc. of the 4<sup>th</sup> European Conference on Structural Dynamics, EuroDyn/99, Prague, 1999.
- [4] Brincker, R., L. Zhang and P. Andersen: "Modal Identification from Ambient Responses using Frequency Domain Decomposition, Proc. of the 18<sup>th</sup> International Modal analysis Conference, San Antonio, Texas, February 7-10, 2000.
- [5] Asmussen, J.C.: "Modal Analysis Based on the Random Decrement Technique, Application to Civil Engineering Structures". Ph.D. Thesis, Aalborg University, Department of Building Technology and Structural Engineering, 1997.
- [6] Brincker, R. and P. Andersen: "ARMA Models in Modal Space", Proc. of the 17<sup>th</sup> International Modal Analysis Conference, Kissimee, Florida, 1999.
- [7] Overschee, Van P., and B. De Moor: " Subspace Identification for Linear Systems", Kluver Academic Publishers, 1996.
- [8] Juang, J.N.: "Applied System Identification", Prentice Hall, Englewood Cliffs, New Jersey, 1994.

Table 1. Test 4. Comparison of identification algorithms

Frequency Domain Decomposition (FDD)		Stochastic Subspace Identification (SSI) Data Driven (DD)		MAC FDD-SSI(DD)	Stochastic Subspace Identification (SSI) Covariance Driven (CD)		MAC FDD-SSI(CD)
Frequency (Hz)	Damping (%)	Frequency (Hz)	Damping (%)		Frequency (Hz)	Damping (%)	
0.174	1.09	0.172	0.42	0.998	0.174	1.04	0.998
0.208	0.58	0.208	0.83	0.999	0.197	0.34	0.555
0.238	0.54	0.236	6.42	0.959	0.236	4.23	0.955
0.281	0.79	0.281	0.50	0.970	0.283	1.31	0.880
0.289	0.40	0.291	4.99	0.323	0.301	1.50	0.204

Table 2. Test 5. Comparison of identification algorithms

Frequency Domain Decomposition (FDD)		Stochastic Subspace Identification (SSI) Data Driven (DD)		MAC FDD-SSI(DD)	Stochastic Subspace Identification (SSI) Covariance Driven (CD)		MAC FDD-SSI(CD)
Frequency (Hz)	Damping (%)	Frequency (Hz)	Damping (%)		Frequency (Hz)	Damping (%)	
0.174	0.83	0.172	0.27	0.998	0.174	0.63	0.999
0.208	0.68	0.209	0.72	0.998	0.207	0.33	0.995
0.239	0.54	0.237	4.66	0.991	0.238	1.29	0.991
0.279	0.44	0.281	0.33	0.998	0.280	0.24	0.982
0.288	0.45	0.288	0.12	0.983	0.289	0.49	0.933

Table 3. Test 6. Comparison of identification algorithms (FDD results in brackets is 2048 point FFT)

Frequency Domain Decomposition (FDD)		Stochastic Subspace Identification (SSI) Data Driven (DD)		MAC FDD-SSI(DD)	Stochastic Subspace Identification (SSI) Covariance Driven (CD)		MAC FDD-SSI(CD)
Frequency (Hz)	Damping (%)	Frequency (Hz)	Damping (%)		Frequency (Hz)	Damping (%)	
0.174	0.64 (0.51)	0.174	0.32	0.996	0.174	0.46	0.998
0.207	0.38 (0.29)	0.208	0.32	0.999	0.208	0.20	0.997
0.239	0.52 (0.38)	0.234	3.94	0.987	0.238	1.63	0.996
0.281	1.16 (0.57)	0.281	0.56	0.994	0.280	0.15	0.979
0.288	0.32 (0.23)	0.288	0.08	0.995	0.288	0.18	0.809

Table 4. Test 7. Comparison of identification algorithms

Frequency Domain Decomposition (FDD)		Stochastic Subspace Identification (SSI) Data Driven (DD)		MAC FDD-SSI(DD)	Stochastic Subspace Identification (SSI) Covariance Driven (CD)		MAC FDD-SSI(CD)
Frequency (Hz)	Damping (%)	Frequency (Hz)	Damping (%)		Frequency (Hz)	Damping (%)	
0.174	0.93	0.174	0.82	0.993	0.174	0.67	0.998
0.207	0.37	0.208	0.34	1.000	0.208	0.30	0.999
0.238	0.39	0.234	5.54	0.965	0.235	0.83	0.985
0.279	0.37	0.280	0.48	0.995	0.282	0.57	0.975
0.288	0.40	0.287	0.14	0.887	0.291	0.61	0.952

Table 5. Values of mean and standard deviation of the damping ratio over the four test cases.

Mode	Frequency Domain Decomposition (FDD)		Stochastic Subspace Identification (SSI) Data Driven (DD)		Stochastic Subspace Identification (SSI) Covariance Driven (CD)	
	Mean value (%)	Standard deviation (%)	Mean value (%)	Standard deviation (%)	Mean value (%)	Standard Deviation (%)
1	0.87	0.19	0.46	0.25	0.70	0.24
2	0.50	0.15	0.55	0.26	0.29	0.06
3	0.50	0.07	5.14	1.08	2.00	1.53
4	0.69	0.36	0.47	0.10	0.57	0.53
5	0.39	0.05	1.33	2.44	0.70	0.70
Mean		0.16		0.83		0.61
Minimum		0.07		0.10		0.06
Maximum		0.36		2.44		1.53

FDD Mode Shape - mode # 1,  $f = 0.17391$  Hz,  $z = 1.0871$  %

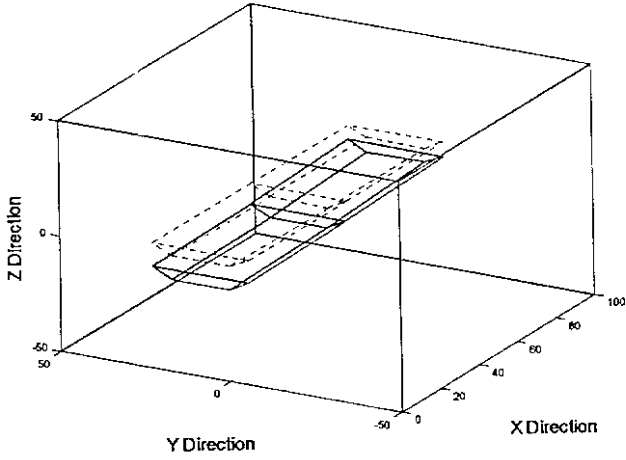

SSI Mode Shape - mode # 1,  $f = 0.17246$  Hz,  $z = 0.41761$  %

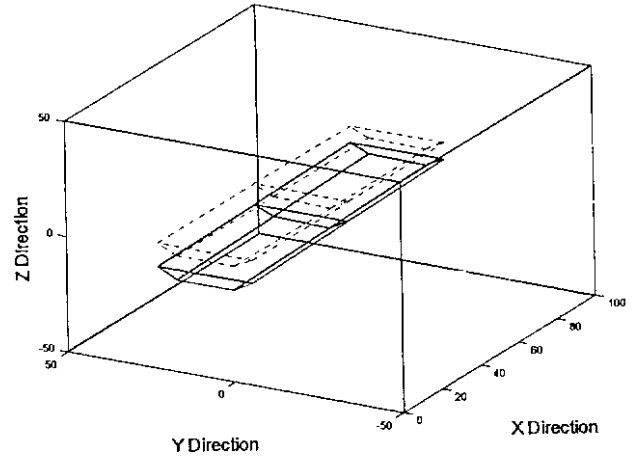

FDD Mode Shape - mode # 2,  $f = 0.2077$  Hz,  $z = 0.57873$  %

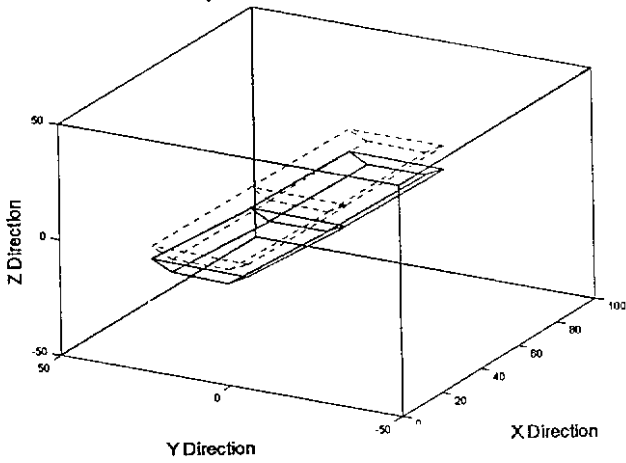

SSI Mode Shape - mode # 2,  $f = 0.20809$  Hz,  $z = 0.82606$  %

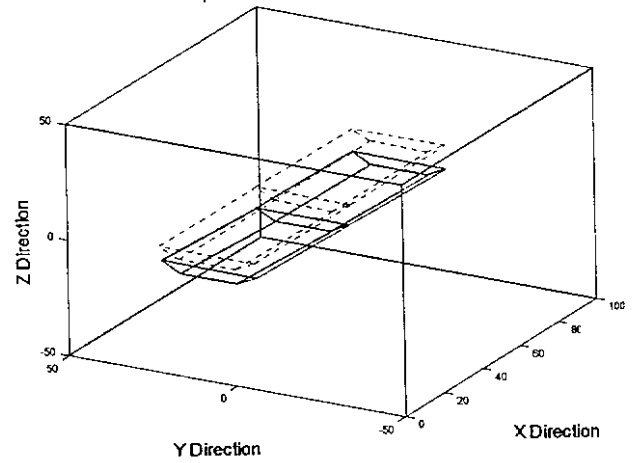

FDD Mode Shape - mode # 3,  $f = 0.23837$  Hz,  $z = 0.5365$  %

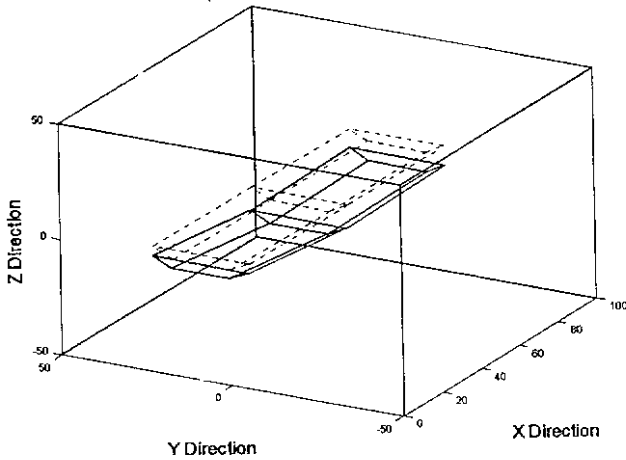

SSI Mode Shape - mode # 3,  $f = 0.23593$  Hz,  $z = 6.4146$  %

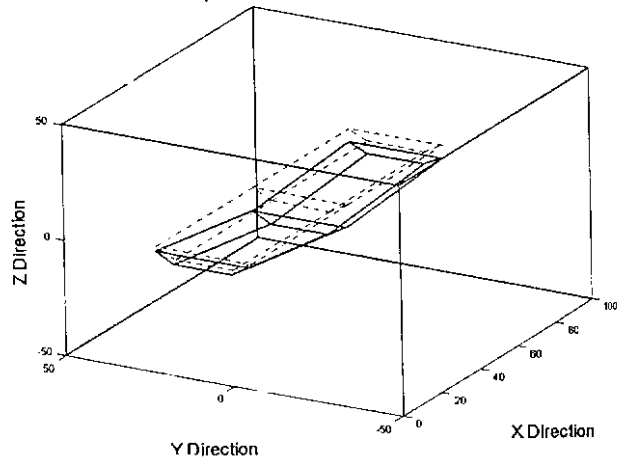

Figure 5: Mode shapes for the first three modes. Left: Frequency Domain Decomposition (FDD). Right: Stochastic Subspace Identification (SSI), data driven.