

ESTIMATION OF CORRELATION FUNCTIONS BY THE RANDOM DECREMENT TECHNIQUE

Rune Brincker, Steen Krenk and Jakob Laigaard Jensen

UNIVERSITY OF AALBORG
Sohngaardsholmsvej 57, DK-9000 Aalborg, Denmark

Abstract

The Random Decrement (RDD) Technique is a versatile technique for characterization of random signals in the time domain. In this paper a short review of the theoretical basis is given, and the technique is illustrated by estimating auto-correlation functions and cross-correlation functions on modal responses simulated by two SDOF ARMA models loaded by the same bandlimited white noise. The speed and the accuracy of the RDD technique is compared to the Fast Fourier Transform (FFT) technique. The RDD technique does not involve multiplications, but only additions. Therefore, the technique is very fast - in some case up to 100 times faster than the FFT technique. Another important advantage is that if the RDD technique is implemented correctly, the correlation function estimates are unbiased. Comparison with exact solutions for the correlation functions show that the RDD auto-correlation estimates suffer from smaller estimation errors than the corresponding FFT estimates. However, in the case of estimating cross-correlations functions for stochastic processes with low mutual correlation, the FFT technique might be more accurate.

Nomenclature

t, τ : time
 i, j, m : subscripts
 $X(t)$: stochastic process
 $x(t)$: continuous time series
 x_m : sampled time series
 $D_{XY}(\tau)$: RDD signature
 $\hat{D}_{XY}(\tau)$: RDD estimate

σ_X^2 : variance on $X(t)$

$R_{XY}(\tau)$: correlation function

$\hat{R}_{XY}(\tau)$: correlation function estimate

N : number of trig points

M : number of points in estimate

Δt : sampling interval

σ_W^2 : window variance

$\sigma_{\dot{X}}^2$: variance on $\dot{X}(t)$

ω_i : natural frequency

T_i : natural period

ζ_i : damping ratio

Φ, Θ : ARMA parameters

ϵ : estimation error

1. Introduction

The Random Dec Technique was developed at NASA in the late sixties and early seventies by Henry Cole and co-workers [1-4]. The purpose was to develop a simple and fast data analysis algorithm for the characterization of stochastic response of space structures and aeroelastic systems and to identify damage in such systems by identifying system changes. Since then, the technique has been used for many purposes, ranging from system identification of large structures, Ibrahim [5] and structural damage detection to determination of fluid damping, Yang, [6-8], vehicle system identification and damping measurements of soil [9-10].

The basic idea of the technique is to estimate a co-called Random Dec signature which can be used to characterize stochastic time series. If the time series $x(t)$, $y(t)$ are given, then the Random Dec signature estimate $\hat{D}_{XY}(\tau)$ is formed by averaging N segments of the time series $x(t)$

$$\hat{D}_{XY}(\tau) = \frac{1}{N} \sum_{i=1}^N x(\tau + t_i) | C_{y(t_i)} \quad (1)$$

where the time series $y(t)$ at the times t_i satisfies the trig condition $C_{y(t_i)}$, and N is the number of trig points. The condition might be that $y(t_i) = a$ (the level crossing condition), or that $y(t_i) = 0 \wedge \dot{y}(t_i) > 0$ (the zero crossing condition with positive slope) or some similar condition. The algorithm is illustrated in figure 1. In eq. (1) a cross signature is estimated since the accumulated average calculation and the trig condition are applied to two different time series. If instead the trig condition is applied to the same time series as the data segments are taken from, an auto signature is estimated.

The advantage of the technique is that it establishes a basis for simple and fast on-line system identification. Because of the simple algorithm it can be programmed in any language using only a few programming lines. It involves only additions, not multiplications like the FFT technique, therefore having the potential of being fast. Moreover it works directly in the time domain, which is often an advantage when identifying system changes, especially when changes in damping ratios are of importance.

However, one of the problems of the technique is that the theoretical basis is still being disputed. In all the references mentioned above, the authors argue on a more or less heuristic basis that the Random Dec signature formed by averaging time series segments from the output of a stochastic loaded system should describe system properties only. This was shown to be incorrect by Vandiver et al, [11], who proved that under certain conditions (applying the level crossing trig condition to a Gaussian process) the Random Dec signature is simply proportional to the auto-correlation function. Vandiver's proof is simple and convincing directly involving the Gaussian distribution and the derivation of closed form solutions for the variance on the estimate. However, the general problem of the interpretation of RDD cross signatures, and the practical problems arising from applying the trig conditions on sampled time series was not addressed. In practise the trig condition must be formulated by use of a finite size window (see next section). The choice of window is essential for the successful use of the RDD technique on sampled time series, since the finite size windows will introduce additional variance and sometimes also bias the estimate, Brincker et al [14], [15].

In Brincker et al [15] the results of Vandiver are generalized to the case of cross signatures, and general trig conditions. Furthermore in [15] some relations are given for general processes and general trig conditions, and solutions for variance and bias introduced by finite size trig windows are derived. In the following some of these results are shortly summarized and the potential of the technique is illustrated by application of the level trig conditions on simulated time series.

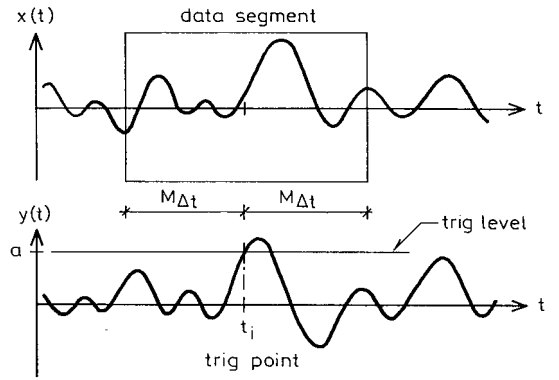

Figure 1. The Random Decrement technique.

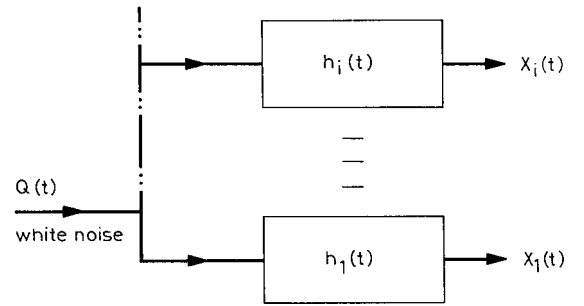

Figure 2. Modal responses $X_i(t)$ determined by loading SDOF systems by white noise.

2. Theoretical Basis

The investigations in this paper will be restricted to the level trig condition. For this condition the mathematical definition of the RDD signature reads

$$D_{XX}(\tau) = E[X(t + \tau) | X(t) = a] \quad (2)$$

where $X(t)$ is a stationary stochastic process and a is the trig level. Vandiver et al. [11] showed that if $X(t)$ is a stationary Gaussian process, then the RDD signature $D_{XX}(\tau)$ and the auto-correlation function $R_{XX}(\tau)$ are related by

$$D_{XX}(\tau) = \frac{R_{XX}(\tau)}{\sigma_X^2} a \quad (3)$$

where σ_X^2 is the variance of the process $X(t)$. In this case, therefore, the function given by eq. (1) is simply an estimate of the auto-correlation function $R_{XX}(\tau)$.

In Brincker et al [15] it is shown that the corresponding formulas for the general case of two stationary Gaussian processes $X(t)$, $Y(t)$ are

$$\begin{aligned} D_{XY}(\tau) &= E[X(t+\tau)|Y(t)=a] \\ &= \frac{R_{XY}(\tau)}{\sigma_Y^2} a \end{aligned} \quad (4)$$

For a sampled finite time series however, the event $y(t) = a$ has the probability zero, and therefore as mentioned above, the condition must be modified by introduction of a finite size window. A finite size horizontal window is introduced by the condition

$$C_{y_i}^H : (y_i \leq a \wedge y_{i+1} > a) \vee (y_i > a \wedge y_{i+1} \leq a) \quad (5)$$

valid for sampled data with and without quantization errors. To prevent bias, the trig point is placed in the middle of the window by averaging two adjacent segments, Brincker et al [15]

$$\hat{D}_{XY}(m\Delta t) = \sum_i x_{m+i} + x_{m+i+1} | C_{y_i}^H, \quad -M \leq m \leq M \quad (6)$$

where Δt is the sampling interval. Assuming the data segments to be independent, the variance of the estimate can be estimated by

$$\text{Var}[\hat{D}_{XY}(\tau)] = \frac{\sigma_X^2}{N} \left(1 - \left(\frac{R_{XY}(\tau)}{\sigma_X \sigma_Y}\right)^2\right) + \sigma_W^2 \quad (7)$$

where σ_W^2 is the variance introduced by the finite size window

$$\sigma_W^2 = \frac{\Delta T^2}{12N} \sigma_Y^2 \left(\frac{R_{XY}(\tau)}{\sigma_Y^2}\right)^2 \quad (8)$$

and where σ_Y^2 is the variance of the derivative process $\dot{Y}(t)$.

3. ARMA model simulation

A set of modal responses $X_i(t)$ are created by loading SDOF systems with natural frequencies ω_i and damping ratios ζ_i by the same stationary Gaussian white noise $Q(t)$, see figure 2. For this case the analytical solutions for the cross-correlation functions are given by, Madsen et al [16], (sec. 8.3)

$$R_{X_i X_j}(\tau) = \pi S_i (\alpha_{ij} g_i(\tau) + \beta_{ij} h_i(\tau)); \quad \tau \geq 0 \quad (9)$$

where S_i is the white noise spectral density, $g_i(\tau)$ is the

free decay for a unit displacement, and $h_i(\tau)$ is the impulse response function

$$\begin{aligned} S_i &= \frac{2}{\pi} \sigma_{X_i}^2 \zeta_i \omega_i^3 \\ g_i(\tau) &= \exp(-\zeta_i \omega_i \tau) \left(\cos(\omega_{di} \tau) + \frac{\zeta_i \omega_i}{\omega_{di}} \sin(\omega_{di} \tau) \right) \\ h_i(\tau) &= \frac{1}{\omega_{di}} \exp(-\zeta_i \omega_i \tau) \sin(\omega_{di} \tau) \end{aligned} \quad (10)$$

and where the factors α_{ij} and β_{ij} are given by

$$\begin{aligned} \alpha_{ij} &= \frac{4(\omega_i \zeta_i + \omega_j \zeta_j)}{(\omega_i^2 - \omega_j^2)^2 + 4\omega_i \omega_j (\omega_i \zeta_j + \omega_j \zeta_i)(\omega_i \zeta_i + \omega_j \zeta_j)} \\ \beta_{ij} &= \frac{2(\omega_j^2 - \omega_i^2)}{(\omega_i^2 - \omega_j^2)^2 + 4\omega_i \omega_j (\omega_i \zeta_j + \omega_j \zeta_i)(\omega_i \zeta_i + \omega_j \zeta_j)} \end{aligned} \quad (11)$$

For $\tau < 0$ the indicis i and j are interchanged in eq. (9). Note the symmetry relations $\alpha_{ij} = \alpha_{ji}$ and $\beta_{ij} = -\beta_{ji}$.

The system responses were simulated using a (2,1) ARMA model given by

$$x_m = \Phi_1 x_{m-1} + \Phi_2 x_{m-2} + a_m - \Theta a_{m-1} \quad (12)$$

where Φ_1 , Φ_2 are the Auto Regressive (AR) parameters, Θ is the Moving Average (MA) parameter and a_m is a time series of independent Gaussian distributed numbers. The model is denoted (2, 1) since it has 2 AR parameters and 1 MA parameter. If the ARMA parameters are chosen as

$$\Phi_1 = 2 \exp(-u) \cos(v) \quad (13.a)$$

$$\Phi_2 = \exp(-2u) \quad (13.b)$$

$$\Theta = -P \pm \sqrt{P^2 - 1}; \quad |\Theta| < 1 \quad (13.c)$$

where

$$P = \frac{\omega_{di} \sinh(2u) - \zeta_i \omega_i \sin(2v)}{2\zeta_i \omega_i \sin(v) \cosh(u) - 2\omega_{di} \sinh(u) \cos(v)}$$

$u = \zeta_i \omega_i \Delta t$ and $v = \omega_{di} \Delta t$, then the ARMA model given by eq. (12) is the representation of the continuous system in the discrete time space. It can be shown, Pandit [18], that the discrete auto-correlation function of the time series x_m given by eq. (12) is equal to the sampled auto-correlation function of the corresponding continuous process.

The simulations were performed using the PC version of the MATLAB software package, [17], except the algorithm for estimation of the RDD signatures which was programmed in the C programming language and linked to the MATLAB software by the MATLAB user function interface. When cross-correlation functions were estimated from two system responses, the sampling interval Δt was taken as one tenth of the shortest natural period of the systems.

4. Typical RDD results

A typical result for estimation of cross correlation functions by the Random Decrement technique is shown in figure 3. Two responses $x_1(t)$ and $x_2(t)$ were simulated, using the system parameters $T_1 = 2\pi/\omega_1 = 1$ s, $T_2 = 2\pi/\omega_2 = 2$ s, and $\zeta_1 = \zeta_2 = 0.05$. The cross-correlation estimate $\hat{R}_{X_1X_2}$ was determined using the trig level $a = \sigma_{X_2}$ and time series of 100.000 data points, corresponding to approximately 3 hour records.

Figure 4 shows the corresponding auto-correlation estimate $\hat{R}_{X_1X_1}$. The estimate was obtained by estimating a set of RDD estimates $\hat{R}_{X_1X_1}^k$, $k = 1, 2, \dots, 100$ from time series of 1000 data points each. From this set of estimates the mean and the empirical variance was calculated. Figure 4 show the mean of the RDD estimates and the standard deviation on $\hat{R}_{X_1X_1}^k$. The theoretical variance was determined from eq. (7) and (8) using the Gaussian properties $\sigma_{\hat{X}_1} = -R''_{X_1X_1}(0) = \omega_1^2 \sigma_{X_1}^2$. As it appears from the results, the level of uncertainty is well predicted by the theoretical solution. The oscillations in the uncertainty predicted by eq. (7) and (8) however, does not appear in the empirical results. This discrepancy is due to the strong correlation between data segments.

The high efficiency of the RDD technique is illustrated by comparing estimation times with the Fast Fourier Transform (FFT) technique, Brigham [12]. Auto-correlation function estimates were obtained from time series of 4000 points. FFT estimates were obtained in the following way. First, the 4000 points were divided into segments of $2M$ points each. Then the segments were FFT'ed, multiplied by their complex conjugate, the results were averaged and the resulting power spectrum was then transformed back to the time domain by inverse FFT. A radix-2 FFT algorithm was used in all cases. No spectral windows was used.

Figure 5 shows the CPU-times as a function of the length of estimated auto-correlation function. There are two curves for the RDD algorithm, one from an earlier investigation, Brincker et al [14], where a floating point implementation was used, and one from a new integer implementation of the RDD algorithm, both corresponding to a trig level of $a = 1.5\sigma_X$. Comparing the CPU results for the FFT algorithm and the integer implementation of the RDD algorithm show that for short estimates the RDD algorithm is orders of magnitude faster than the FFT algorithm. For $M = 16$ the CPU-time for the RDD estimates were about a factor 120 shorter than for the FFT estimates, and the corresponding factor for $M = 32$ was found to about 50. However, since reliable estimates for the damping and the natural frequency might be found from short unbiased correlation function estimates, see figure 3 and 4, the RDD technique has a great potential in all cases where speed is essential, for instance in the case of on line system identification.

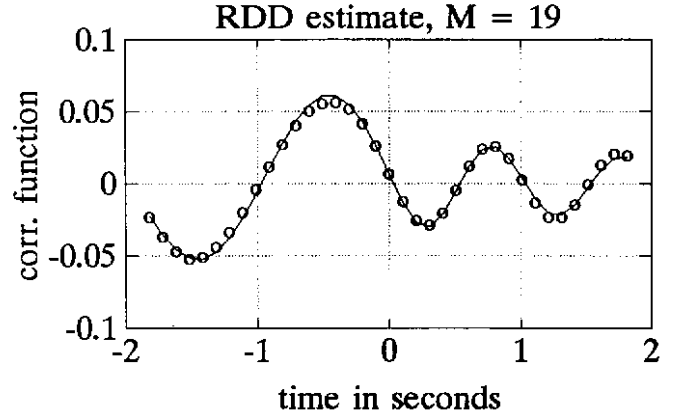

Figure 3. Random Decrement estimate ("o") of cross correlation function, $T_1/T_2 = 2$, $\zeta = 0.05$, compared to analytical solution ("-").

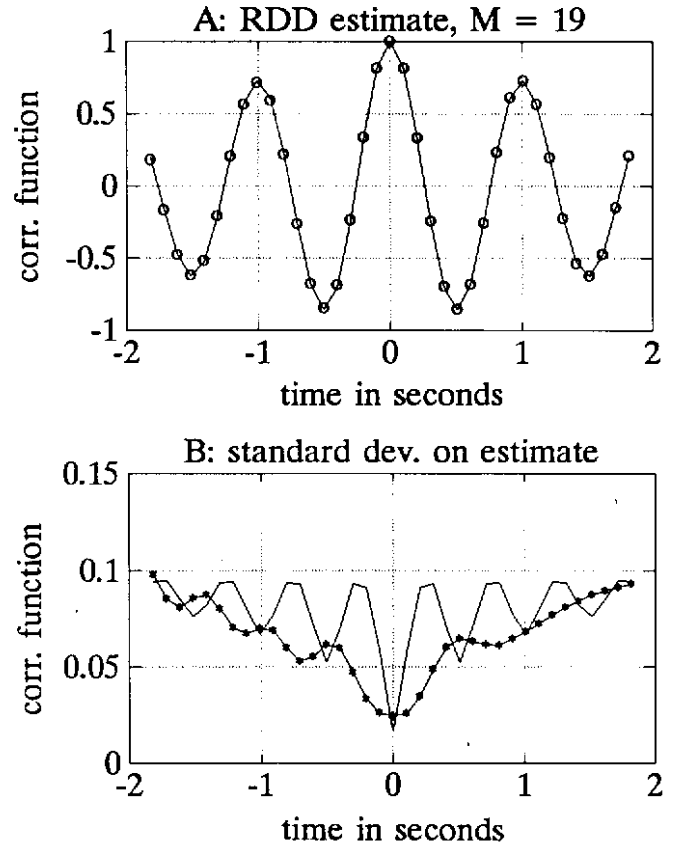

Figure 4. Estimation of auto correlation function. A: comparison between Random Decrement estimate ("o") and exact solution ("-") and B: between theoretical ("-") and empirical ("*") standard deviation.

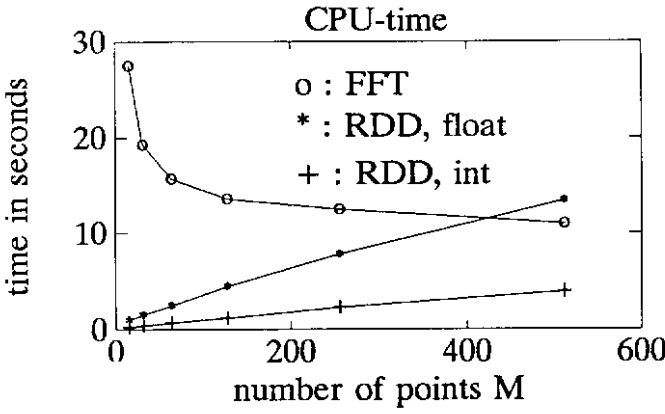

Figure 5. Comparization of CPU times for Fast Fourier Transform and Random Decrement on a time series of 4000 data points.

5. Accuracy of RDD estimates

In this section the accuracy of the Random Decrement technique is compared to traditional FFT estimation, the FFT technique being applied as described in the preceding section. Time series $x_1(t)$ and $x_2(t)$ of 4000 data points were simulated and cross-correlation functions $R_{X_1 X_2}$ were estimated, the RDD technique using the trig level $a = 1.5\sigma_{X_2}$.

The influence of the length of the correlation function estimates on the estimation error has already been reported, Brincker et al [14]. Therefore, only the influence of the damping ratio and the system difference $(T_2 - T_1)/T_1$ on the estimation error is investigated here. When the system difference is zero it corresponds to the case of estimating auto-correlation functions. The estimation error ϵ is defined as

$$\epsilon = \frac{\sigma}{\max(R_{X_1 X_2}(\tau))},$$

$$\sigma^2 = \frac{1}{2M-1} \sum_{m=-M}^M (\hat{R}_{X_1 X_2}(m\Delta t) - R_{X_1 X_2}(m\Delta t))^2 \quad (14)$$

describing the average error per point in relation to the maximum value of the correlation function.

The FFT estimation errors for $M = 16$ and $M = 128$ are shown in figure 6. As it appears from these results, the error for long estimates does not seem to be sensitive to the correlation between the time series, only in the case of low damping ($\zeta = 0.01$) there is a significant increase in estimation error for increasing system difference. In the case of short estimates there is a significant dependency for both small and medium damping ($\zeta = 0.01, \zeta = 0.05$). The oscillatory behaviour of the results in figure 6.A is not valid in general, but is governed by the degree of fulfillment of the assumption of periodicity of the correlation function changing more or less arbitrarily with the system difference parameter $(T_2 - T_1)/T_1$ (note that the sampling period Δt is taken as the smallest of the natural periods - therefore the sampling period is changing with the system difference

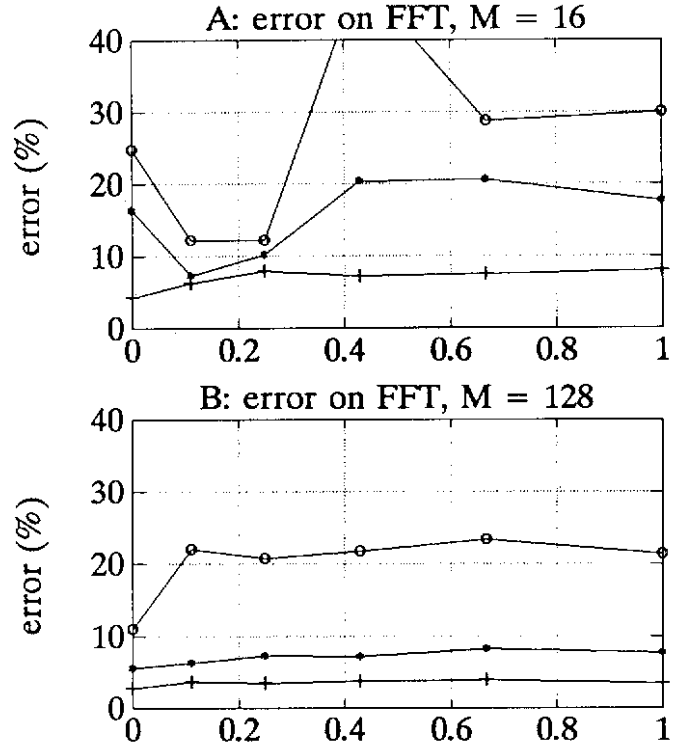

Figure 6. Estimation errors on Fast Fourier Transform estimates versus $(T_1 - T_2)/T_1$ for A: $M = 16$ (data segment length) and B: $M = 128$. $\zeta = 0.01$ ("o"), 0.05 ("*") and 0.25 ("+").

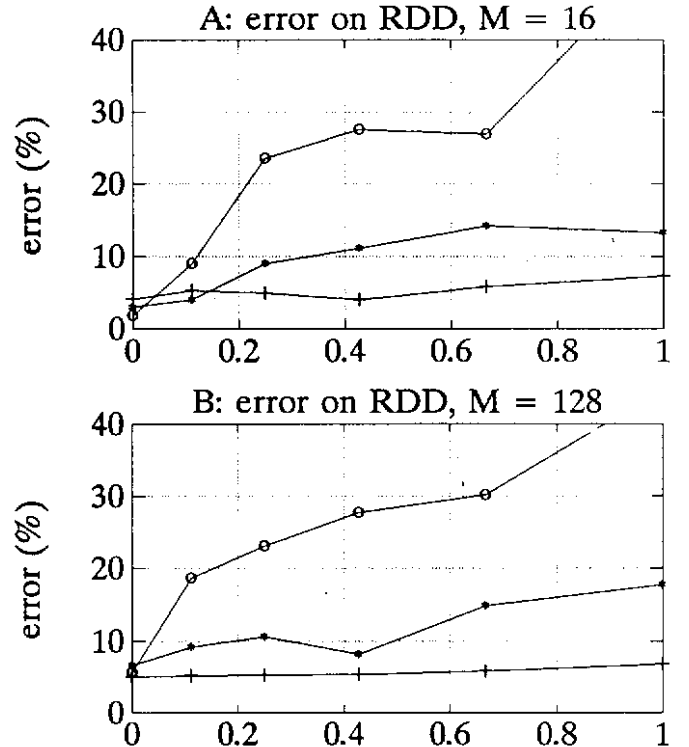

Figure 7. Estimation errors on Random Decrement estimates versus $(T_1 - T_2)/T_1$ for A: $M = 16$ (data segment length) and B: $M = 128$. $\zeta = 0.01$ ("o"), 0.05 ("*") and 0.25 ("+").

parameter, and so is the degree of fulfillment of the assumption of periodicity of the correlation function).

The corresponding results for the RDD estimates are given in figure 7. As it appears from these results, the dependency of the system difference parameter is significant for small and medium damping ($\zeta = 0.01, \zeta = 0.05$), and is about the same for short and long estimates. The errors on the RDD estimates are substantially smaller than the FFT errors for small system differences, but there is a significant increase in the estimation error with increasing system difference, and for a system difference of $(T_2 - T_1)/T_1 = 1$ the FFT technique is superior. It is natural to expect an increase in the estimation error for increasing system difference. When the system difference increases, the correlation between the time series decrease, the values of the correlation function becomes smaller, and therefore the relative error increases.

Conclusions

The Random Decrement technique is a versatile very simple non parametric technique for estimation of auto correlation functions as well as cross-correlation functions.

The technique is simple to implement. If a few simple rules are respected, estimates obtained by the Random Decrement technique will be unbiased, also in the case of low damping and short estimates.

The technique is very fast. If the estimates are short, the estimation algorithm might be more than 100 times faster than Fast Fourier Transform algorithm.

The Random Decrement technique provides an accurate way of estimating auto-correlation functions and cross correlation functions. Especially in the case of low damping and short estimates, the FFT estimates becomes heavily biased, and the RDD technique is superior. However, in the case of estimating cross correlation functions, when the correlation between time series is small, random errors become large in relation to the estimated correlation functions, and therefore, it might be more accurate to estimate cross-correlation functions by the FFT technique.

Acknowledgements

Financial support from the Danish Technical Research Council and the Danish Energy Agency is gratefully acknowledged.

References

- [1] Cole, A. Henry: "On-the-line Analysis of Random vibrations". AIAA/ASME 9th Structures, Structural and Materials Conference, Palm Springs, California, April 1-3, 1968.
- [2] Cole, A. Henry: "Failure Detection of a Space Shuttle Wing Flutter by Random Decrement". NASA, TMX-62,041, May 1971.
- [3] Cole, A. Henry: "On-line Failure Detection and damping Measurement of Space Structures by Random Decrement Signatures". NASA, CR-2205, March 1973.
- [4] Chang, C.S.: "Study of Dynamic Characteristics of Aerodynamic Systems Utilizing Randomdec Signatures". NASA, CR-132563, Febr. 1975.
- [5] Ibrahim, S.R.: "Random Decrement Technique for Modal Identification of Structures". J. Spacecraft, Vol. 14, No. 11, Nov. 1977.
- [6] Yang, J.C.S., J. Chen and N.G. Dagalakis: "Damage Detection in Offshore Structures by the Random Decrement Technique". ASME, Vol. 106, March 1984.
- [7] Yang, J.C.S., N. Dagalakis and M. Hirt: "Application of the Random Decrement Technique in the Detection of a Induced Crack on an Offshore Platform Model". Comput. Methods for Offshore Struct. Winter Annu Meet. of ASME, Nov. 16-21, 1980.
- [8] Yang, J.C.S., C.H. Marks, J. Jiang, D. Chen, A. Elahi and W-H Tsai: "Determination of Fluid Damping Using Random Excitation". ASME, Vol. 107, June 1985
- [9] Siviter, R. and M.G. Pollard: "Measurement of Railway Vehicle Kinetic Behaviour Using the Random Decrement Technique". Vehicle System Dynamics, Vol. 14, No 1-3, June 1985.
- [10] Al-Sanad, A.A., M.S. Aggour and M.I. Amer: "Use of Random Loading in Soil Testing. Indian Geotechnical Journal, Vol. 16, No.2, 1986.
- [11] Vandiver, J.K., A.B. Dunwoody, R.B. Campbell and M.F. Cook: "A Mathematical Basis for the Random Decrement Vibration Signature Analysis Technique" J. Mechanical Design, Vol. 104, April 1982.
- [12] Brigham, E.O.: "The Fast Fourier Transform". Prentice-Hall, Inc., 1974.
- [13] Papoulis, Athanasios: "Probability, Random Variables, and Stochastic Processes". McGraw-Hill, 1984.
- [14] Brincker, R., J.L. Jensen and S. Krenk: "Spectral Estimation by the Random Dec Technique." Proc. 9th Int. conf. on Experimental Mechanics, Copenhagen August 20-24, 1990.
- [15] Brincker, R., S. Krenk and J.L. Jensen: "Theory of the Random Decrement Technique." Submitted to Journal of Sound and Vibration.
- [16] Madsen, H.O., S. Krenk and N.C. Lind: "Methods of Structural Safety". Prentice-Hall, 1986.
- [17] PC-MATLAB for MS-DOS Personal Computers, The Math Works, Inc., 1989.
- [18] Pandit, S.M. and S. WU: "Time Series and System Analysis with Applications". John Wiley and Sons, 1983.